

# Grand Action Touchweight . . . . . © 2006 Bill Spurlock

A working knowledge of touchweight is important for several reasons. First, we often receive comments from pianists that the “touch” of a piano is too heavy or light. The problem may indeed be touchweight; or, factors like voicing, room acoustics or poor regulation might be causing the *sensation* of heavy or light touch. Having the ability to make touchweight measurements and knowing how to interpret them are essential to accurate diagnosis. Secondly, weight, leverage, and friction are important factors in an action's repetition speed. Touchweight measurements can diagnose both weight and friction problems in an action and are thus invaluable in analyzing performance problems. Thirdly, pianos are designed to have a certain touch resistance and key return speed so they will function properly and feel “normal”. Since hammer mass and action leverages have a major effect upon touchweight, this knowledge is essential when selecting and preparing appropriate replacement parts.

## What determines an action's touch?

Touch is affected by action leverages, the weight of action parts and amount of key leading, and friction. We can measure some aspects of touch easily:

► **Downweight** is the weight which, when placed on the end of the key, will just cause the key to depress from the rest position to the point that the jack tender first touches the let-off button.

► **Upweight** is the maximum weight that the key will lift back up to its rest position, starting with the jack just touching the let-off button but *not* tripped. Both measurements are made exclusive of the damper system—with the action on the bench or else with the pedal depressed.

Normally measured in grams, Downweight consists of two components: the resistance due to the *weight* of the hammer and other parts, acting through the action levers, and the resistance due to *friction* (in action centers and between rubbing parts like capstan & wippen felt, knuckle & rep. lever, key pins & key bushings, etc. Thus Downweight = weight + friction, or

$$D = Wt. + F.$$

Likewise Upweight consists of the force provided by the weight of the action parts trying to return to rest, *minus* the resistance to movement due to friction. Thus Upweight = Weight - Friction, or

$$U = Wt. - F$$

Combining these two equations to eliminate Wt. gives the equation (Downweight - Upweight) ÷ 2 = Friction or:

$$F = (D - U)/2$$

If we know what values of D, U, and F are normal, this equation gives us a valuable tool for evaluating actions. *However, these are only static measurements. They will relate to how an action feels when played very slowly, but do not tell us much about how an action will feel when played fast, when **inertia** comes into play.*

► **Inertia** is resistance of mass to acceleration, and is the increased resistance felt when a key is struck hard compared to when it is played softly. Imagine two teeter-totters, one with a 40# child on one end and a 50# child on the other, and another with a 400# Sumo wrestler on one end and a 410# Sumo wrestler on the other. Both teeter-totters are within 10# of being in balance. However, it is apparent that if you walked up behind each and tried to pump them up and down, you could oscillate the children much faster and easier than you could the wrestlers. Likewise action inertia is independent of D and U.

- Some inertia is a necessary and desirable part of all piano touch, providing feedback to the player to judge playing force. However, too much can make an action feel unbearably heavy and tiring when played fast and hard.
- Inertia is the product of both the mass of action parts (mainly hammers and key leads) and the leverages within the action. A high leverage action (one where shallow key dip produces long hammer travel), with heavy hammers and lots of lead, will have high inertia because for a given key travel the hammer accelerates quickly and moves farther.
- An action with very heavy hammers counter-balanced with lots of key leads might have a similar D and U to one with light hammers and few leads, but inertia levels will be far different.
- Inertia varies tremendously across the scale of a given piano from bass notes with large hammers and several leads to treble notes with small hammers with few or no leads.
- Inertia cannot be measured without complicated equipment that “feels” the action while in motion.

However, action leverage can be easily measured, and together with observations of hammer weight and key leading, allows us to predict how an action will feel. Two simple measurements will give us a factor I call **Action Ratio**.

- ▶ **Action Ratio** is the ratio of hammer travel to key travel. It varies from piano to piano depending upon action design. This is a quick and convenient measure of an action's tendency toward inertia and weight problems, and a predictor of what regulation measurements will be necessary for a given action.
  - Ratios measured this way typically range from 5 to 6+
  - Higher ratio actions will require more key leads and lighter hammers to keep downweight low. They will also regulate with less key dip and longer hammer travel, since the higher ratio gives more hammer travel per unit of key dip.
  - Lower ratio actions will require fewer key leads and can tolerate heavier hammers without creating downweight problems. But, they must be regulated with more key dip and less hammer travel to achieve adequate aftertouch.

### What Should These Measurements Be?

- ▶ **Upweight** is actually an indicator of key return speed. A key that can lift a high upweight will have a high return speed; a low upweight indicates slow key return. Upweight is important since an action can only repeat as fast as the keys can return, and key return speed is beyond the pianist's control.
  - 20 grams is usually cited as a minimum upweight for good repetition, although this figure leaves little safety factor; if action pinning tightens up, knuckles become flattened, or as hammers become lighter due to filing, upweight (and key return speed) will decrease.
  - Upweight decreases as hammers become lighter due to wear, since it is primarily the weight of the hammer that pushes down on the capstan to lift a key back up.
  - Increased friction reduces upweight, since action parts must work against friction during key return.
  - Adding lead to the front ends of keys to decrease downweight decreases upweight an equal amount.
  
- ▶ **Downweight** averages around 50 to 60 grams for most modern grand actions in good condition. Leads are inserted into the front halves of the keys during manufacture to overcome the weight of the hammers and other action parts and calibrate the downweight.
  - A 1 gm increase in hammer weight causes a 5 - 7 gm increase in both D and U, and vice-versa. Thus it is important to use replacement hammers of the correct weight in order to avoid an excessively heavy touch. Likewise, as original hammers wear and are filed, the touch becomes lighter. A single moderate filing can lighten a hammer by ¼ gm, and therefore reduce D and U by 1.5gm. With many filings, a hammer can lose over 1 gm in felt, lightening the touch by 5 - 10gm.
  - Increased friction increases downweight.
  
- ▶ **Friction** averages 12 - 15 grams in the bass tapering to 8 - 10 grams in the high treble, for actions in good condition.
  - The main sources of friction *for actions in good adjustment* are, in order of decreasing amount, the knuckle, the hammershank centerpin, wippen centerpin, key bushings, and the capstan. The friction will be higher in the bass for two reasons. First, hammershank pinning is usually tighter in the bass (if all hammer/shank assemblies are pinned to swing the same number of times, heavy bass hammers will require tighter fitting pins than small treble hammers). Second, friction at the knuckle will be greater in the bass, where the heavier hammers push the knuckle against the wippen with more force.
  - The most common causes of excessive friction *in actions needing service* are rubbing action parts between adjacent notes, knuckles contaminated with oil or grease (or lacking *proper* knuckle lubrication), tight key bushings or balance holes, and tight action centers—particularly the hammershank center.
  - Unusually low friction in an individual key is a sure sign of a loose hammershank center.
  - More friction increases downweight and decreases upweight, and vice-versa. Therefore it is critical to measure the friction in an action, using measurements of upweight and downweight and the formula  $F = (D-U)/2$ , as a first step in diagnosing any touchweight problem. *Key weighting should never be changed to correct discrepancies caused by differences in friction from key to key.* Rather, friction should be measured and evened-out first, *then* the upweight and downweight can be evaluated.
  
- ▶ **Inertia** cannot be easily measured, as already mentioned. However, the factors that affect inertia (action ratio, hammer weight, and key leading) *can* be noted.

- ▶ **Action Ratio** generally varies from 5 to 6.2, with most pianos measuring between 5.3 and 5.9.
- Pianos with ratios of around 5 or less will seldom have weight problems, but will suffer from compromises in the regulation, namely very deep key dip and/or short hammer blow distance. Sharps may have to be set extra high to avoid burying when depressed, and power may be reduced due to short hammer blow.
- Pianos with ratios of around 6.2 or higher will tend to feel heavy unless very light weight hammers are used. If desired downweight is achieved by using numerous leads rather than lightening the hammers, the action will feel terribly heavy when played fast. A better compromise is to use fewer leads, allowing a D of 60 - 65, to minimize inertia. This will make the action feel lighter when played fast even though the static measurement of D is high.
- The two easiest ways to change action ratio are changing hammer shank knuckle-to-centerpin distance and capstan position (see Figure 5). This makes choice of proper replacement shanks and wippens critical in rebuilding.
- Spring assist wippens are one tool for improving high inertia actions, since they allow lower D without the added inertia of excessive key leads.

## Making Touchweight Measurements

▶ **Tools:** Upweight and downweight are measured using test weights. Supply houses sell a weight set consisting of one each of 32, 16, 8, 4, 2, and 1 gram weights. These are inexpensive and compact, but are inaccurate unless calibrated by filing or adding solder and checking with a gram scale. They are also very inconvenient to use since you must combine several weights together, then do tedious arithmetic in your head to add up the total. A more efficient alternative is a complete set such as ours (see web site), which requires only one or two weights per measurement.

▶ **Procedure:** Before making measurements, remove the dampers from the system by stepping on the pedal or placing the action on a work bench. Make sure key bushings and balance holes are very free, and that neighboring action parts are not rubbing. For consistency, always place the weights in the same position on each key (flush with the front end is convenient), and always look for a consistent speed of hammer movement when measuring. If tapping the keybed or action rail is necessary to get the parts into motion, excess friction is present. Lubricating the knuckles with our Micro Fine PTFE Powder will improve accuracy and speed the work.

- To measure downweight, place different weights on the end of a key until you find one just heavy enough to cause the key to depress to the point where the jack first touches the let-off button.
- To measure upweight, find the weight that the key will just lift back to rest from the partially depressed position (jack just touching the let-off button). The hammer need not return completely to rest—it usually stops about 1/8" short when the key first contacts the fuzz on the back rail cloth.

## Measuring Action Ratio

▶ **Tools:** 6" metric rule and a home made action ratio tester (see Fig 1 & Fig 2). The action ratio tester is simply a device to easily depress a key by a known amount so that the resulting hammer movement can be measured and the ratio of hammer to key travel can be calculated. I use 6mm, but anything from 5 to 7 would work fine; just not so much that the jack starts to trip. Note that the 6mm block is tapered slightly like a dip block. Note also that the tester is weighted with key leads so it will depress the key the full 6mm.

▶ **Procedure:** Choose a sample natural key note to measure. First check that repetition lever/jack height is correct, the shank is off the rest rail, and the neighboring keys are level. Next adjust the capstan so the hammer is perfectly level with its neighbors. If you are working at the piano, slide the action partway out onto a Keybed Action Support (see web site), or move to a table.

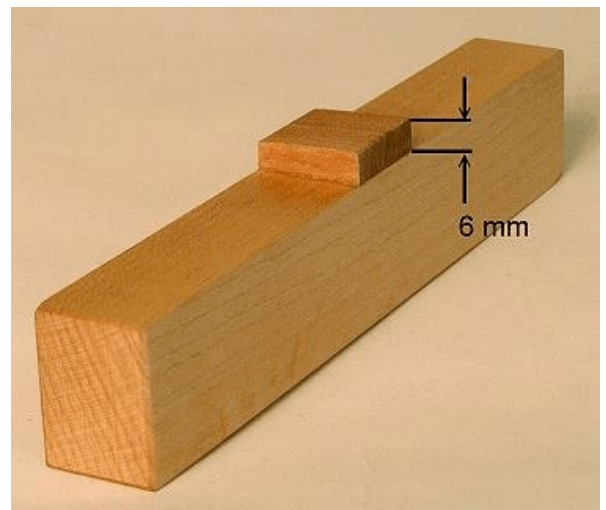

Figure 1: Action Ratio Tester: spans 7 keys, wt: ~90 gm., has 6mm block on bottom. Block is slightly tapered toward the rear (ratio tester is pictured here upside down)

1. Place the ratio tester on the test key as shown in Figure 2.

2. Measure the resulting hammer rise as in Figure 3.
3. Divide the hammer rise by the 6mm key travel to get the action ratio. Test several keys and take an average. Action ratio will vary from note to note due to irregularities in the action such as knuckles, centerpins, capstans and balance rail pins out of line, variations in action spread, etc



Figure 2: The ratio tester automatically depresses a test key 6mm

## Using Touchweight Measurements to Diagnose Action Problems

Before assuming a piano has a touchweight problem, be sure to consider regulation, voicing, and overall piano condition. Accurate regulation, properly shaped and voiced hammers, and solid tuning are much more important to piano performance than the precise level of downweight or inertia in the action.

► **Action feels too heavy:** Measure action ratio (R), then measure downweight (D), upweight (U), and compute friction (F) for several keys.

1. If R and D are actually in the normal range, the action might just *feel* heavy if the piano lacks power due to poor hammers, voicing, poor regulation, worn action parts, or poor soundboard or structural condition. Or, the pianist may be comparing the touch to what it was before replacement of worn (light weight) hammers. Another possibility is that heavy replacement hammers have been installed, and extra key leads added to keep the downweight normal. The result can be excessive inertia, making the action feel heavy even though static measurements show a normal D.
2. If R is average but D is abnormally high, look at the hammers, key leading, and F. If the friction is much over 15 grams in the bass or 12 grams in the treble it is at least part of the problem. Check for tight key bushings, balance pin holes, and action centers; lubricate the knuckles with powdered PTFE. If you cannot identify any reason for the high F, suspect contamination of the knuckles and/or wippen cushions with an oily substance. Eliminate this possibility by replacing one knuckle with a new one, sanding and re-graphiting the rep. lever, and re-measuring that note.
3. If F is OK, the problem is usually due to over-weight replacement hammers and/or R too high. There are four possible solutions: (1) replace with more appropriate hammers; (2) remove weight from the existing hammers by tail shaping, tapering, removing excess wood from inside the tails, extra filing and removing the staples (see Fig. 4); (3) Modify action ratio by moving the capstans or knuckles (see Figure 5); (4) add key leads. Adding extra key leads is the wrong choice if there is average leading already in the keys, since this increases inertia and may actually cause an even heavier feeling action.

► **Action feels too light:**

- If D is normal, the action may have a low R and/or very light hammers and fewer than average key leads, causing low inertia. Or, the pianist may just be accustomed to a piano with a heavier touch.
- If D is low the most likely cause is very worn or severely filed hammers. One filing can easily remove enough felt to lower the touchweight by 2 grams, so 50 year old hammers may be worn enough to cause a touchweight 10 grams lighter than original. Very loose hammer shank centers will also cause a low D by reducing friction.

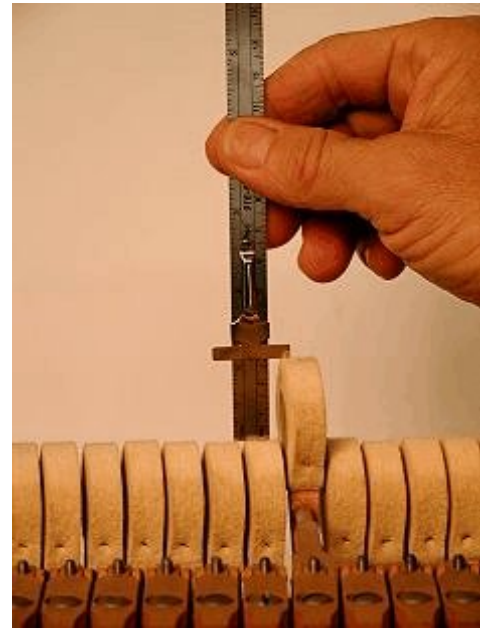

Figure 3: Measuring the hammer movement resulting from the 6mm key travel of the ratio tester

► **Action has poor repetition:**

Inspect for worn parts and poor regulation. Measure D and U, and compute F. Assuming action condition and regulation are OK, a likely cause of poor repetition is slow key return which will show up as a low upweight measurement (less than about 18 grams).

- Low U can be caused by either high friction, hammers that are too light, or excessive lead added to keys.
- If F is normal and D is low, U can be increased by removing some key leads. This will increase both D and U, and will decrease inertia as well.

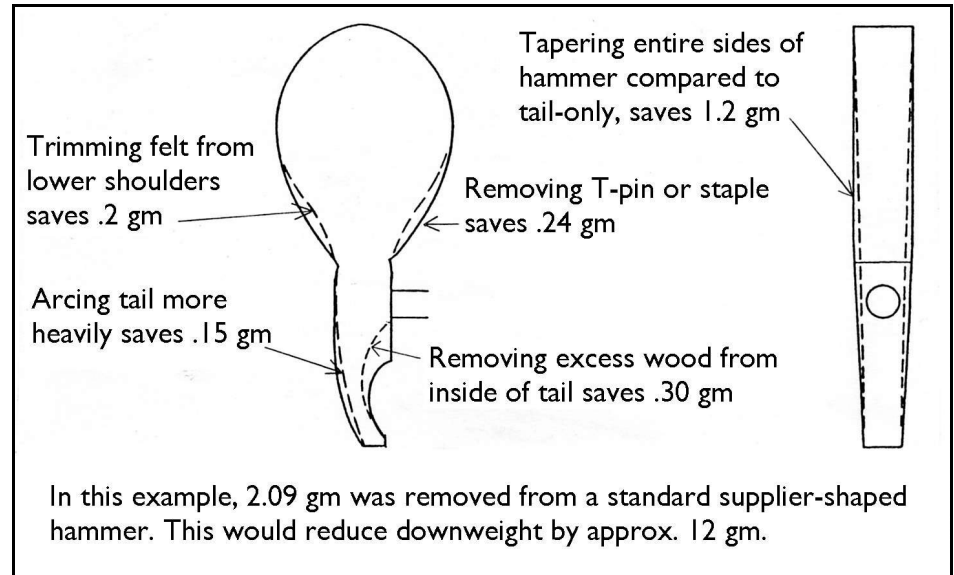

Figure 4: The Effect Of Various Shaping Operations On Touchweight

## Doing Better Action Rebuilding

In addition to diagnosing action problems, a knowledge of touchweight allows us to do much better action repair work by choosing appropriate replacement hammers and action parts, paying attention to action ratio, and correcting uneven friction. And, although not necessary for every job, we can re-weight the keyboard after parts replacement so downweight, upweight, friction and inertia are all uniform from note to note. This adds the finishing touch to a complete action rebuilding job by calibrating the key weighting to match the replacement parts.

► **Using touchweight considerations in choosing and preparing new hammers:** In general, many replacement hammers will be heavier than those originally installed on vintage pianos. Expect the touchweight to be high when installing modern hard-pressed hammers on a 70 year old action. You can minimize weight problems by choosing mahogany, walnut, or soft maple moldings over birch, hard maple, or hornbeam, and by removing as much excess weight as practical in the tail shaping process. Avoid hammers that are wider or larger than originals. *For more information see my publication "Grand Hammers: boring, tail shaping, & installation" (see web site).*

When selecting new replacement hammers, you can evaluate samples to see if they will be of appropriate weight using the following procedure:

1. If wippens, shanks & flanges or knuckles are to be replaced with non-identical parts, or if the existing parts are very worn, fit new action parts to sample spots in the action.
2. File, bore, and shape tails of several new sample hammers and dry-fit them in proper position on the sample shanks.
3. Regulate the sample keys, then measure R, D, U and find F. Correct F if out of limits and re-measure D and U. Note: To minimize capstan friction, the capstan/wippen contact point should cross the line of centers (Figure 5) at some point in the key travel. If it does not at least come within 2mm of the line, you may want to correct this by a different choice of wippen heel, knuckle diameter, hammer bore, or by changing the height of the action brackets on the key frame.
4. Evaluate R, D and U using the guidelines on page 2. If D is excessive for these samples, you will have to either remove more weight from the hammers, choose lighter hammers, or lower the action ratio. R can be reduced by either moving the capstan or choosing shanks with a different knuckle position (or moving the knuckles in the shanks if others are not available. Moving capstans is the simpler option.) Remember that a very low action ratio will require deep key dip and short hammer blow. You don't get something for nothing!
5. If U is less than 20 grams, you will have to either install heavier hammers, shape the hammers less severely, remove some leads from the keys, or raise the action ratio if it is on the low side.

### ► Using Touchweight Measurements In Action Rebuilding:

In many cases the procedure above may be adequate to ensure an acceptable touch on a rebuilt action. The appropriate choice of hammers and parts, and uniform tail shaping and tapering to ensure uniform hammer weights, combined with good regulation and voicing, will yield a touch that equals or exceeds original manufacturing standards for many pianos.

For better quality pianos and more serious pianists, you may want to go further by making touchweight measurements on all 88 keys on the completed action to locate and correct variations in friction. And, for the ultimate job you might want to adjust both friction and key weighting as necessary so downweight, upweight, friction, and inertia vary smoothly across the scale.

This work is essential if we are to do the best possible job on a quality grand piano. The value of this procedure is that it identifies differences in friction and touchweight that we would otherwise not be aware of, and allows us to add another dimension of evenness to an action.

On the other hand, this additional work goes beyond what many manufacturers do, even on higher grade instruments. I feel it is important to keep some perspective on this work: Just because measurements can detect imperfection does not necessarily mean that corrective work will provide every customer with additional benefit for the extra cost.

Where going beyond the original manufacturer's tolerances is warranted, I suggest the following procedure:

1. Rebuild the action, taking care that hammershank pinning is as even as possible, capstans and keypins are polished, and repetition and jack tops are smooth and well burnished. Space action parts and bench regulate the action. If the piano is available, install the action and pound in a tuning to settle the new action parts, then re-regulate.
2. Before taking touchweight measurements, eliminate any obvious sources of friction:
  - Key bushings *must* have slight play. Lubricate keypins with dry PTFE spray or McLube 1725.
  - Wool fibers on closely spaced action parts can rub, causing surprising amounts of friction. Using an electric burn-in knife or flame heated knife, iron down the fuzz on the sides of hammers, knuckles, repetition lever cushions, and key end felts to eliminate all contact between neighboring parts. *Don't even bother taking measurements until you have done this step.*
  - Lubricate the knuckles; talc is OK but our Micro-Fine PTFE Powder is far better (see web site). Avoid touching knuckles with your fingers—a little moisture or oil from the skin can temporarily add 2 gm of friction to a note. If the action has not been played at all, burnish the knuckles against the repetitions by rocking the key and hammer together, as if you were checking backcheck to hammer tail clearance.
- Re-check parts spacing, key height, repetition lever height, and capstan height. (Dip, let-off, drop, etc. have no effect upon touchweight measurements and so do not need to be exact at this time.)

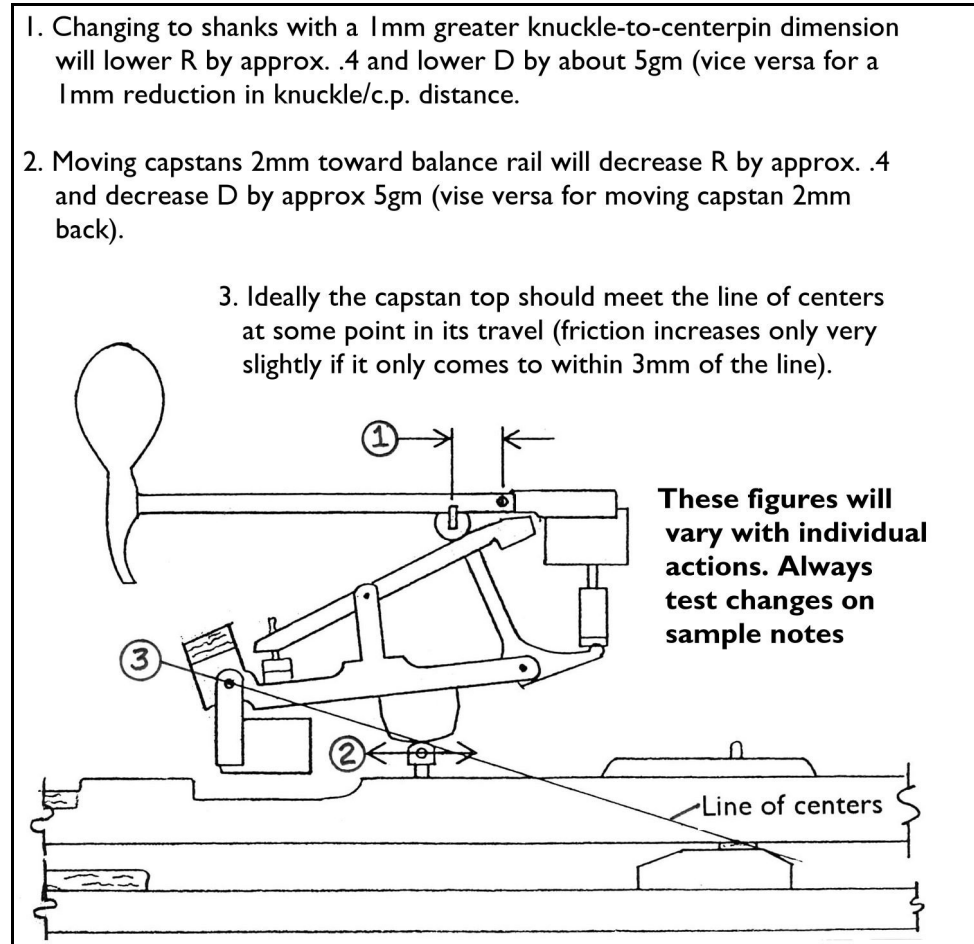

Figure 5: Two methods of changing action ratio

3. Measure D and U on all 88 keys, recording measurements on a work sheet as attached. As you proceed, if you come across a key that weighs much heavier than the others you should check again for adequate clearance in the key bushings. Also check for rubbing between neighboring action parts by depressing adjacent keys; if that causes the heavy key to move faster, it is a sure sign of rubbing parts.

4. Compute F for each key. Look over the friction measurements and decide how much friction there should be in each area of the action. Different actions will have different friction levels due to variations in action geometry, parts materials, and hammer weight. Looking at the figures, you should see most of the F values in the low bass are 12 - 15gm. Find one bass note with a lower F and one with a higher F, remove their shanks and test the pinning by swinging. You will probably find the note with a low F to have loose pinning, and that with a higher F to have either tight pinning or a snug key bushing. By inspecting a few notes with friction that is different from the average in each section, you will be able to see what F is normal for that particular action in the bass, tenor, and treble.

5. Find and correct the problem on any notes that have friction levels out of the ordinary. For instance, looking at the data in Figure 6, I would correct notes 2, 4, and 7 because their F's are higher than average. I would also check hammer pinning on note 5 because its F is lower than average. Do not expect to be able to achieve absolutely uniform friction from key to key. Slight differences in capstan location, key angle, texture of knuckle leather, etc. will cause differences in friction between adjacent notes for which you cannot account; a  $\pm 1$  gram tolerance is fine. *To emphasize the point once again, the object of making these measurements is to be able to identify the friction level in each note so that it can be made uniform. Only then can we proceed to adjust key weighting if necessary to achieve uniform D and U.*

6. Re-measure D and U for any notes on which you corrected friction problems. You are now ready to look at downweight and upweight and possibly make some changes. If your new hammers match the weight of the originals, and the original factory key weighting was properly done, your job may be finished. That is, your D and U figures will be fairly uniform, D will be in the desired range and U will be 20 grams or more.

Often, however, you will want to change the original key weighting for one of the following reasons:

- Sometimes the original weighting was poorly done. The symptom of poor original key leading is that D and U figures are very erratic even though your friction, hammer shaping, and action geometry are even from note to note. In such cases you will find that the original key leads do not follow a uniform pattern of placement in the keys. This is a sure indicator that the original leads were installed simply to give a uniform downweight without first making friction (or wippen assist springs if present) uniform. The result can be uniform D but very erratic U, and uneven inertia caused by varying amounts of lead in adjacent keys.
- Even if you chose and shaped hammers carefully, original key leading can often be improved to best match your new hammers and action parts. For example, you might have deliberately gone to lighter-than-original hammers so that you could remove some leads from the keys and still have normal D and U, thereby reducing inertia in the action.
- Your customer may have specifically requested a heavy or light touch. Here you need to proceed cautiously, since the different tone and response of a rebuilt action will greatly influence the player's perception of the piano's touch. If possible, they should play the action in its rebuilt form before you agree to deliberately modify it further. Remember that adding lead to the keys to reduce downweight will also reduce upweight, and U should be at least 20 grams or more.
- Most often, you will be doing relatively minor key re-weighting, adding some leads and removing others just to make the action as uniform as possible.

ACTION WEIGH-OFF DATA SHEET			
note#	D	U	F
1	56	24	16
2	58	22	18
3	55	24	15½
4	60	22	19
5	50	24	13
6	55	24	15½
7	58	21	18½
8	53	23	15

Figure 6: Touchweight measurements recorded on data sheet

7. Remove a lead or two from any keys with D and U measurements that are lower than desired, using a punch as shown at right. Some leads are installed in blind holes; for these drill a small hole in the lead, insert a wood screw, and pull out with a nail pulling bar.

Minor increases in D and U can be made by simply drilling into the end of a lead with a bit slightly smaller than the lead diameter.

8. You are now ready to calibrate each key to a uniform downweight. (Since you have already made friction uniform, you will automatically be making upweight and inertia uniform as well). Place a test weight, equal to your desired downweight, on the end of a key you wish to adjust. Then position a key lead somewhere on the front half of the key such that the key just drops. This indicates the correct position in which to install that lead into the key. Note the lead location by lifting the key slightly and marking the side of the wood with chalk. Space leads at least one lead diameter apart to avoid weakening the key. Proceed across the entire keyboard in this fashion. Try to keep the lead locations fairly uniform from key to key. In other words, try to accomplish your re-weighting with leads of similar size and location to those in surrounding keys. For minor changes, small  $3/8$ " leads are useful.

9. Remove the keys and drill holes for the new leads. You will usually be using  $1/2$ " or  $3/8$ " leads. Forstner bits are best here; they drill the cleanest holes and do not splinter the key as they exit. To minimize weakening of the keys, be sure to center the holes top-to-bottom.

10. Swage the new leads into place, being careful not to over-do it and split the keys. I like to back the lead up with a  $1/2$ " (or  $3/8$ ") steel rod set to protrude slightly from a hardwood block as shown at right; this ensures that the lead will not protrude from one side of the key.

To further reduce the danger of splitting the key wood, you can make a punch like that shown which expands the lead more fore & aft against the end grain and less top-to-bottom.

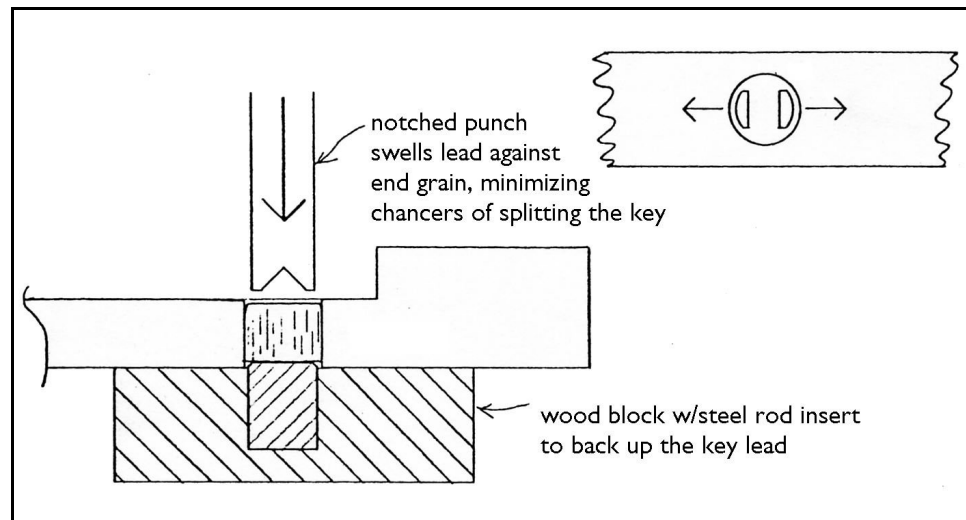

Figure 8: Swaging new leads in place.

11. Holes left empty after removal of original leads can be plugged if desired, using plugs cut from similar wood with grain direction matching that of the keys. This is a good idea if the keys show any splitting between leads, or if you have drilled new holes close by.

This completes the re-weighting job. The action now has uniform resistance to touch across the keyboard. Friction and upweight are uniform, so key return speed is even and predictable. The weight of action parts and key leads varies smoothly across the keyboard, so inertia is uniform except for minor variations in action ratio that all actions have. Together with careful regulation and voicing, the piano action will now be extremely even, allowing the pianist maximum control over dynamics and technique.

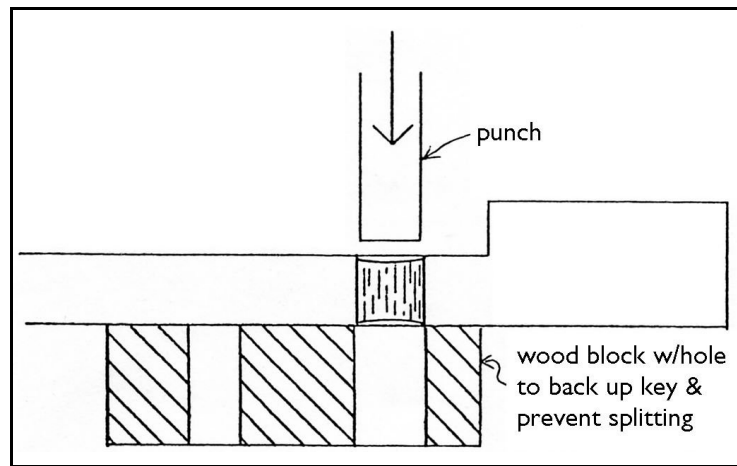

Figure 7: Removing leads from keys.



## Touchweight Data Sheet

Piano:

Action Ratio:

Note	D	U	F	Note	D	U	F	Note	D	U	F
1				30				59			
2				31				60			
3				32				61			
4				33				62			
5				34				63			
6				35				64			
7				36				65			
8				37				66			
9				38				67			
10				39				68			
11				40				69			
12				41				70			
13				42				71			
14				43				72			
15				44				73			
16				45				74			
17				46				75			
18				47				76			
19				48				77			
20				49				78			
21				50				79			
22				51				80			
23				52				81			
24				53				82			
25				54				83			
26				55				84			
27				56				85			
28				57				86			
29				58				87			